

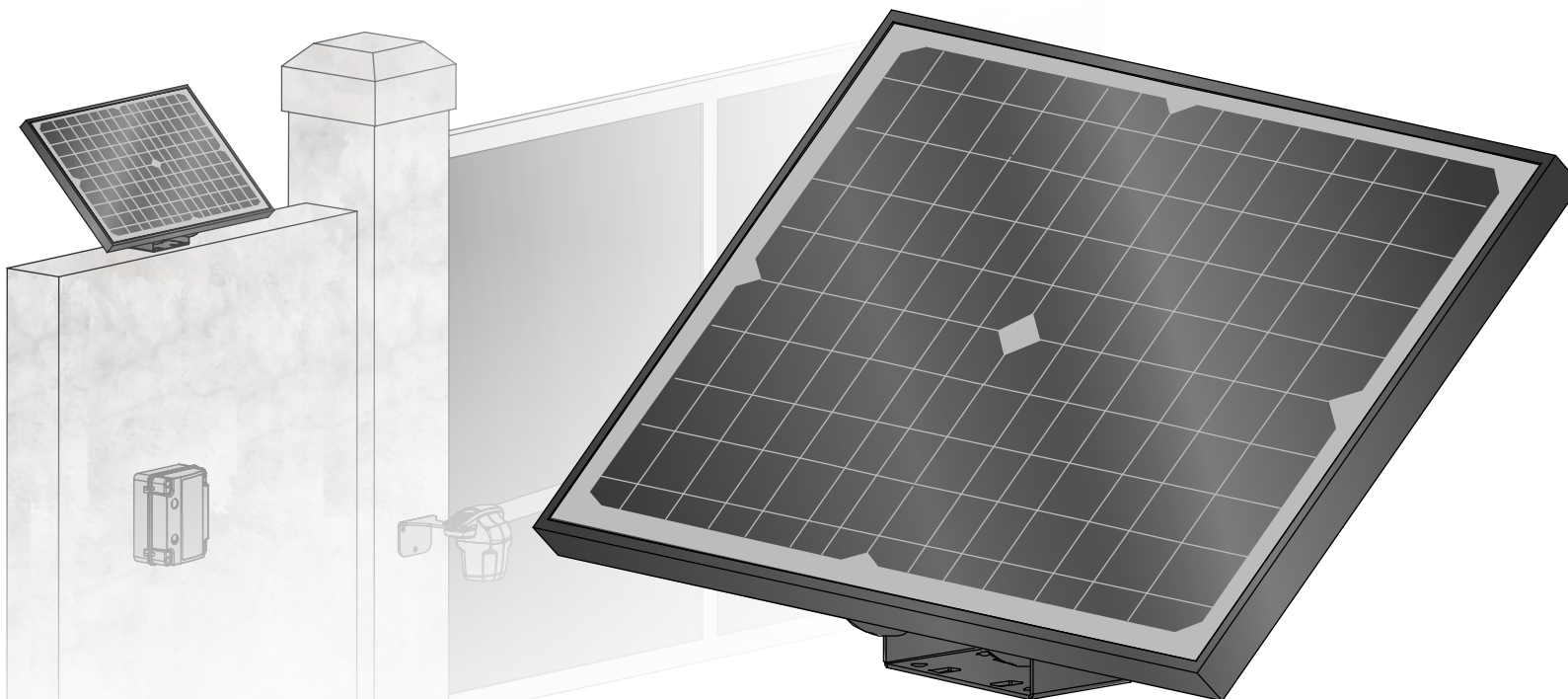

APOLO

USER/INSTALLER MANUAL



01. SAFETY INSTRUCTIONS	1
02. APOLO	
FEATURES	4A
CONNECTORS	5A
03. INSTALLATION	
SOLAR PANEL POSITIONING	5B
INSTALLATION MAP	6A
FIXATION	6A
04. PROGRAMMING	
PROGRAMMING REMOTE CONTROLS	7B
POWER SUPPLY	8A
DELAY	8A
05. BATTERY	
BATTERY STATUS	8B
06. CONNECTIONS SCHEME	
CONNECTIONS MAP OF MCHSOLAR WITH MC60	9
CONNECTIONS MAP OF MCHSOLAR WITH MC62	10

ATTENTION:



This product is certified in accordance with European Community (EC) safety standards.



This product complies with Directive 2011/65/EU of the European Parliament and of the Council, of 8 June 2011, on the restriction of the use of certain hazardous substances in electrical and electronic equipment and with Delegated Directive (EU) 2015/863 from Commission.



(Applicable in countries with recycling systems).
This marking on the product or literature indicates that the product and electronic accessories (eg. Charger, USB cable, electronic material, controls, etc.) should not be disposed of as other household waste at the end of its useful life. To avoid possible harm to the environment or human health resulting from the uncontrolled disposal of waste, separate these items from other types of waste and recycle them responsibly to promote the sustainable reuse of material resources. Home users should contact the dealer where they purchased this product or the National Environment Agency for details on where and how they can take these items for environmentally safe recycling. Business users should contact their vendor and check the terms and conditions of the purchase agreement. This product and its electronic accessories should not be mixed with other commercial waste.



This marking indicates that the product and electronic accessories (eg. charger, USB cable, electronic material, controls, etc.) are susceptible to electric shock by direct or indirect contact with electricity. Be cautious when handling the product and observe all safety procedures in this manual.

GENERAL WARNINGS

- This manual contains very important safety and usage information. Read all instructions carefully before beginning the installation/usage procedures and keep this manual in a safe place that it can be consulted whenever necessary.
- This product is intended for use only as described in this manual. Any other enforcement or operation that is not mentioned is expressly prohibited, as it may damage the product and put people at risk causing serious injuries.
- This manual is intended firstly for specialized technicians, and does not invalidate the user's responsibility to read the "User Norms" section in order to ensure the correct functioning of the product.
- The installation and repair of this product may be done by qualified and specialized technicians, to assure every procedure are carried out in accordance with applicable rules and norms. Nonprofessional and inexperienced users are expressly prohibited of taking any action, unless explicitly requested by specialized technicians to do so.
- Installations must be frequently inspected for unbalance and the wear signals of the cables, springs, hinges, wheels, supports and other mechanical assembly parts.
- Do not use the product if it is necessary repair or adjustment is required.
- When performing maintenance, cleaning and replacement of parts, the product must be disconnected from power supply. Also including any operation that requires opening the product cover.
- The use, cleaning and maintenance of this product may be carried out by any persons aged eight years old and over and persons whose physical, sensorial or mental capacities are lower, or by persons without any knowledge of the product, provided that these are supervision and instructions given by persons with experienced in terms of usage of the product in a safe manner and who understands the risks and dangers involved.
- Children shouldn't play with the product or opening devices to avoid the motorized door or gate from being triggered involuntarily.

WARNINGS FOR TECHNICIANS

- Before beginning the installation procedures, make sure that you have all the devices and materials necessary to complete the installation of the product.
- You should note your Protection Index (IP) and operating temperature to ensure that is suitable for the installation site.
- Provide the manual of the product to the user and let them know how to handle it in an emergency.
- If the automatism is installed on a gate with a pedestrian door, a door locking mechanism must be installed while the gate is in motion.
- Do not install the product "upside down" or supported by elements do not support its weight. If necessary, add brackets at strategic points to ensure the safety of the automatism.
- Do not install the product in explosive site.
- Safety devices must protect the possible crushing, cutting, transport and danger areas of the motorized door or gate.
- Verify that the elements to be automated (gates, door, windows, blinds, etc.) are in perfect function, aligned and level. Also verify if the necessary mechanical stops are in the appropriate places.
- The central must be installed on a safe place of any fluid (rain, moisture, etc.), dust and pests.
- You must route the various electrical cables through protective tubes, to protect them against mechanical exertions, essentially on the power supply cable. Please note that all the cables must enter the central from the bottom.
- If the automatism is to be installed at a height of more than 2,5m from the ground or other level of access, the minimum safety and health requirements for the use of work equipment workers at the work of Directive 2009/104/CE of European Parliament and of the Council of 16 September 2009.
- Attach the permanent label for the manual release as close as possible to the release mechanism.

- Disconnect means, such as a switch or circuit breaker on the electrical panel, must be provided on the product's fixed power supply leads in accordance with the installation rules.
- If the product to be installed requires power supply of 230Vac or 110Vac, ensure that connection is to an electrical panel with ground connection.
- The product is only powered by low voltage safety with central (only at 24V motors)

WARNINGS FOR USERS

- Keep this manual in a safe place to be consulted whenever necessary.
- If the product has contact with fluids without being prepared, it must immediately disconnect from the power supply to avoid short circuits, and consult a specialized technician.
- Ensure that technician has provided you the product manual and informed you how to handle the product in an emergency.
- If the system requires any repair or modification, unlock the automatism, turn off the power and do not use it until all safety conditions have been met.
- In the event of tripping of circuits breakers or fuse failure, locate the malfunction and solve it before resetting the circuit breaker or replacing the fuse. If the malfunction is not repairable by consult this manual, contact a technician.
- Keep the operation area of the motorized gate free while the gate in in motion, and do not create strength to the gate movement.
- Do not perform any operation on mechanical elements or hinges if the product is in motion.

RESPONSABILITY

- Supplier disclaims any liability if:
 - Product failure or deformation result from improper installation use or maintenance!
 - Safety norms are not followed in the installation, use and maintenance of the product.
 - Instructions in this manual are not followed.
 - Damaged is caused by unauthorized modifications
 - In these cases, the warranty is voided.

MOTORLINE ELECTROCELOS SA.

Travessa do Sobreiro, nº29
4755-474 Rio Côvo (Santa Eugénia)
Barcelos, Portugal

SYMBOLS LEGEND:



• Important safety notices



• Useful information



• Programming information



• Potentiometer information



• Connectors information



• Buttons information

KIT APOLO is a solar energy system for low voltage (LV) automations. Suitable for gates far from the electrical network and to simplify installations when it is impossible to pass electrical cables. The controller allows switching off the engine control board whenever it is in standby. In this way, all automation components are without power, leading to energy savings, increasing energy efficiency and battery life. Other features that stand out:

- Durability and longer battery life
- Includes battery discharge protection system
- Superior battery capacity – 12Ah
- Ease of installation
- Provides more savings and energy efficiency

CONFIGURATION INFORMATION

For a better configuration of the system, we recommend that you activate the automatic closing setting for the shortest possible time, so that the control board does not remain connected for too long to power the accessories continuously. If it is a door that remains open for long periods, you can use the opening limit switch or the multifunction outputs and send a signal to the **APOLO KIT** control board (**MCHSOLAR**) to turn it off when it is in the open position.

However, if you use a continuous external impulse such as, for example, a timer clock and the control board does not switch off on opening, remove the impulse for it to close again using the automatic closing logic.

Whenever sun exposure is less than 20 hours/15 days, it is prudent to place 2 panels in parallel, in order to obtain a higher charging current and, consequently, a faster battery charge.



It is only possible to use door status input in MCHSOLAR, **when the motors have limit switches on opening and closing**. If the motors do not have limit switches (e.g.: swing gate motors), the closing order can only be sent via the multifunctional outputs or using position sensors or magnetic contacts. The use of automatic closing is also required in this mode.

FUNCTIONS AND FEATURES

- Regulate the energy of the solar panel;
- Monitor and charge the battery;
- Manage the power to the control board that controls the motor, turning off the power supply when the system is not in use;
- Process opening and closing impulses;
- Built-in receiver;
- Low battery indicator;
- Battery deep discharge protection;
- Delay adjustment for start order;
- Adjustment of the time between the closing order and the power cut.

BOX APOLO TECHNICAL INFORMATION

• Rated voltage	24Vdc
• Output current	10A
• Battery capacity	12Ah//14Ah
• Protection class	IP65
• Operating temperature (battery)	Discharge: -20° ~ 60°C Charge: -10° ~ 60°C Storage: -20° ~ 60°C
• Weight	6KG
• Dimension	300mm x 250mm x 120mm
• Standby consumption	0.15W
• Solar panel maximum voltage	50V
• Solar panel max. current	2A
• Solar panel max. power	2 x 30W
• Battery voltage	24V
• Maximum output power	240W
• Operating temperature	-25° to +55°C
• Fuse	10A
• Built-in radio receiver	433.92 MHz
• Compatible remote controls	12bits or Rolling Code
• Maximum memory capacity	100(full opening) – 100(pedestrian opening)

TECHNICAL INFORMATION MSP30-72A (SOLAR PANEL)

• Maximum output power (Voc)	30W
• Short circuit current (Isc)	0.916A
• Maximum power voltage (Vmp)	36.0V
• Maximum power current (Imp)	0.833A
• Test Temperature (Tc)	25°C
• Weight	3.3KG
• Dimension	355mm x 540mm x 25mm
• Cable length	3m
• Cable section	2x1mm

CONNECTORS

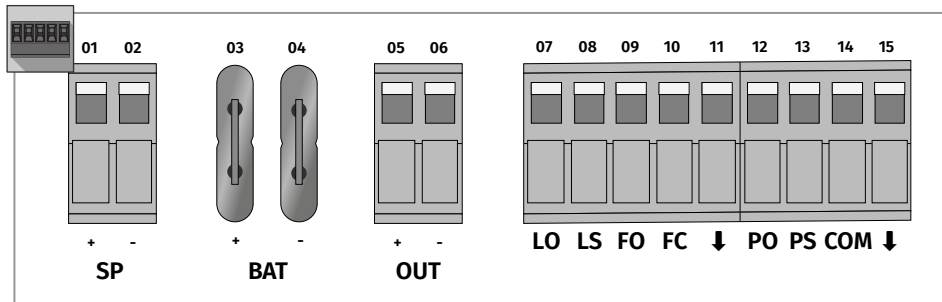

SP	01 • Input for solar panel (positive pole) 02 • Input for solar panel (negative pole)
BAT	03 • Battery input (positive pole) 04 • Battery input (negative pole)
OUT	05 • Power output for the control board (positive pole) 06 • Power output for the control board (negative pole)
LO	07 • NO input for complete maneuver button
LS	08 • NO input for pedestrian maneuver button
FO	09 • Input for opening limit switch
FC	10 • Input for closing limit switch
→	11 • COM
PO	12 • Impulse output for complete maneuver
PS	13 • Impulse output for pedestrian maneuvering
COM	14 • Common impulse outputs
→	15 • COM

The orientation and inclination of the solar panel depends on where you are in the world. **In the northern hemisphere, the panel must face south and vice versa.**

The solar panel should be located in a shade-free area, away from trees and tall structures, which could create shade at some time of the day or year.

It is extremely important to remember that the path of the sun is higher during the summer months and there may not be as many shadows in a given area, but in winter there is, due to the fact that the sun is lower. Also, trees can grow and create larger shadows over time.

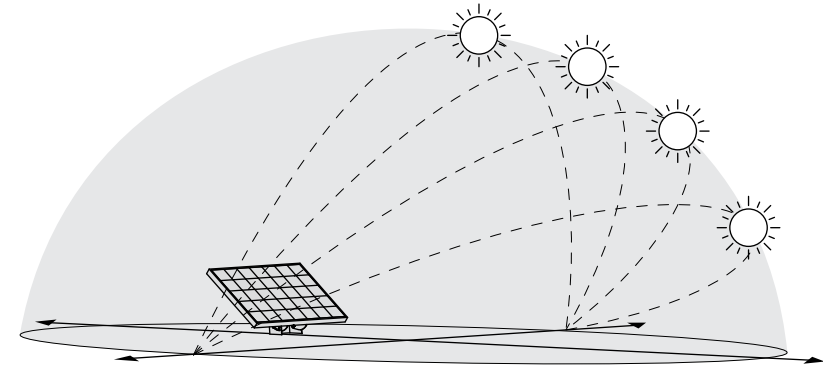

PANEL TILT BY LOCATION

In order to ensure that **the panel is at a 45° angle to the sun**, follow the indication in the table below.

City	α
• Lisbon	38°
• Rome	41°
• Milan	45°
• London	51°
• Washington	46°
• Paris	48°
• Berlin	52°
• Madrid	40°
• Amsterdam	52°
• Brussels	50°

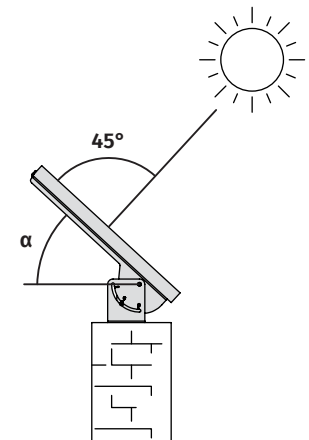

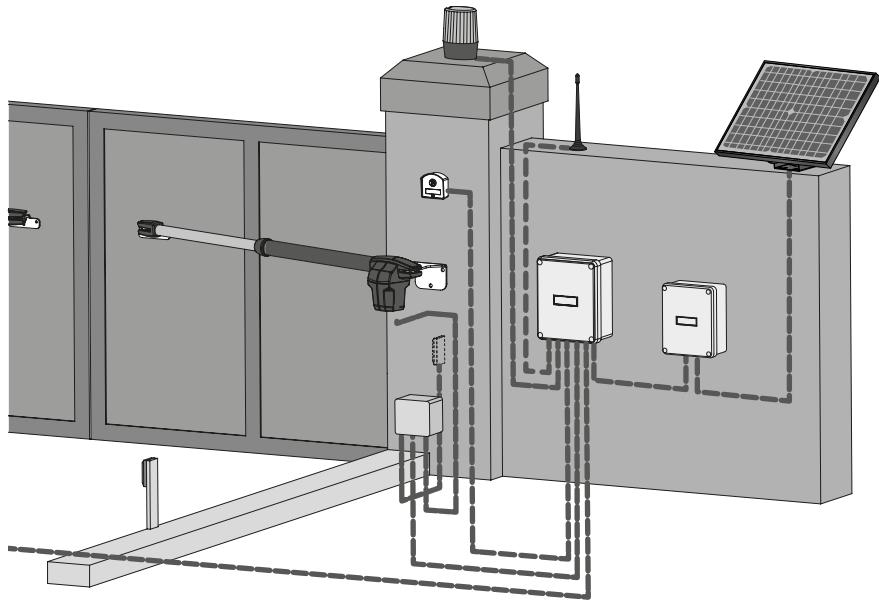

COMPONENTS TO FIX

(Measurements in mm)

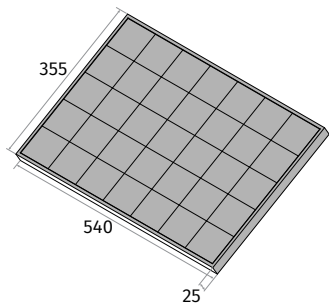

SOLAR PANEL

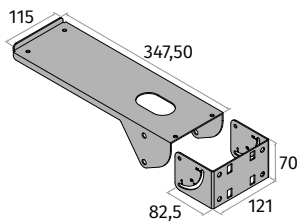

SOLAR PANEL FIXING SUPPORT

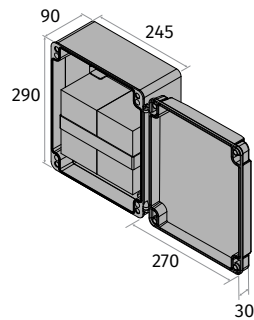

BOX

PANEL SUPPORT FIXATION

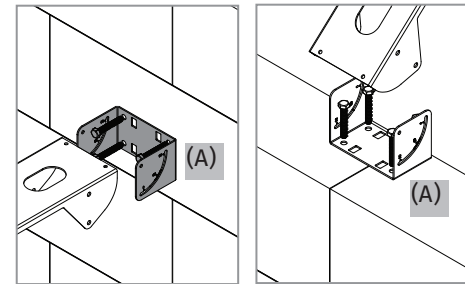

1. Fix the fixing plate **(A)** to the wall, using the screws (not included) indicated for the surface.

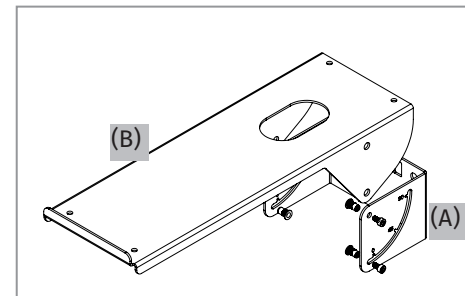

2. Place the support **(B)** on the already fixed plate, with the screws (M5 x 12mm DIN912) that come with the product.

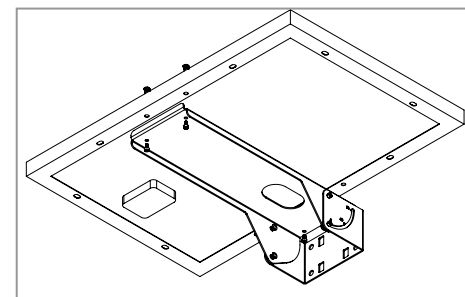

3. Place the panel on the support and fix it with the screws (M5 x 12mm DIN912) that come with the product.

 Possibility of fixing to a tube, with the aid of clamps (not included), as in the side image.

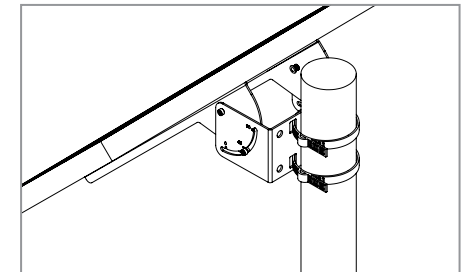

BOX FIXATION

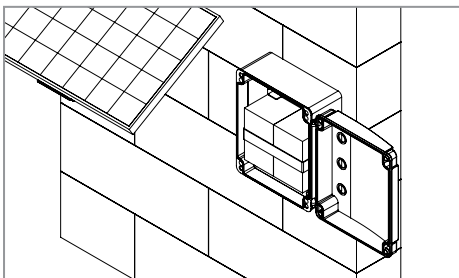

1. Fix the box in an area close to the solar panel, making the necessary holes with screws indicated for the surface.

BATTERY CONNECTION



Batteries are shipped from the factory with the connection cable disconnected, so as not to waste energy during transport. In the image, check the cable (K) that interconnects the 2 batteries and must be connected.

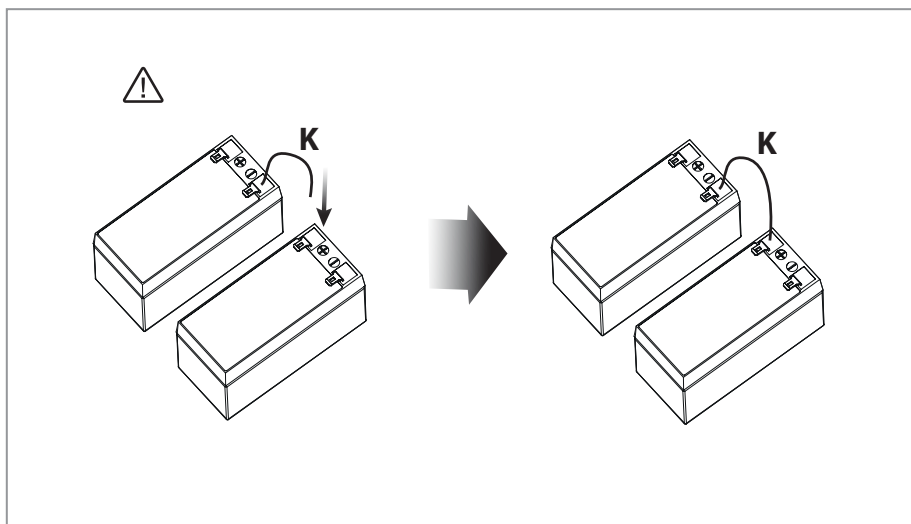

The APOLO system is only compatible with **Motorline or 12 Bits** remote controls.

PROGRAMMING REMOTE CONTROLS FOR FULL OPENING

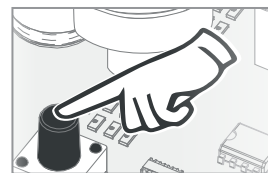

1. Press the LEARN button once, the LED will flash with an interval of 0.5 seconds.

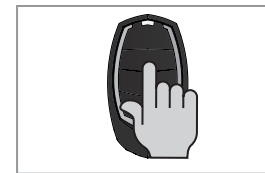

2. Press the remote control button you want to program.

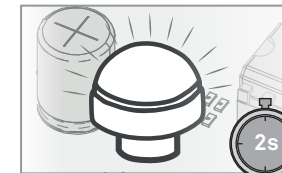

3. The LED will be on for 2 seconds to confirm the operation.

PROGRAMMING REMOTE CONTROLS FOR PEDESTRIAN OPENING

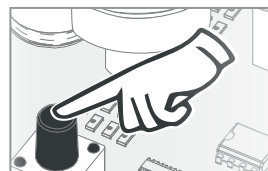

1. Press the LEARN button for 2 seconds until the LED flashes at a 0.2 second interval.

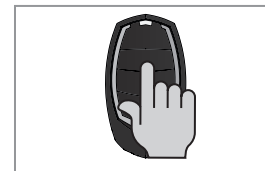

2. Press the remote control button you want to program.

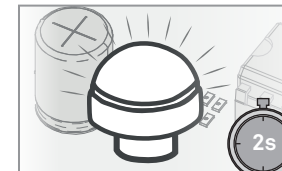

3. The LED will be on for 2 seconds to confirm the operation.

ERASE ALL THE REMOTE CONTROLS

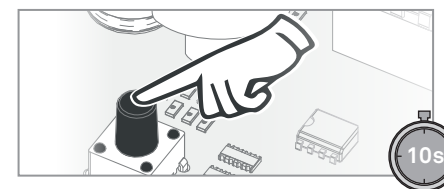

1. Press the LEARN button for 10 seconds.

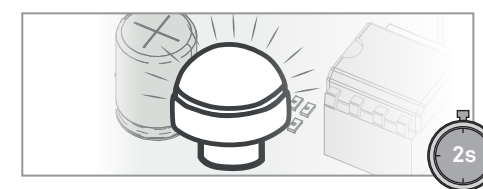

2. The LED will be on for 2 seconds to confirm the operation.

CONTINUOUS / LOW CONSUMPTION POWER SUPPLY



In order to be able to program the course in the control board, the supply needs to be continuous and without interruption, so there is a jumper that allows you to define whether the output has continuous supply or low consumption.

POWER SUPPLY	
CONTINUOUS	LOW CONSUMPTION
<p>(JMP)</p>	<p>(JMP)</p>

• Jumper (JMP) in position 1-2 provides continuous power to the control panel.

• When programming is finished, place the jumper (JMP) in position 2-3, so that the control board can enter low consumption mode.



The jumper leaves the factory with continuous power.

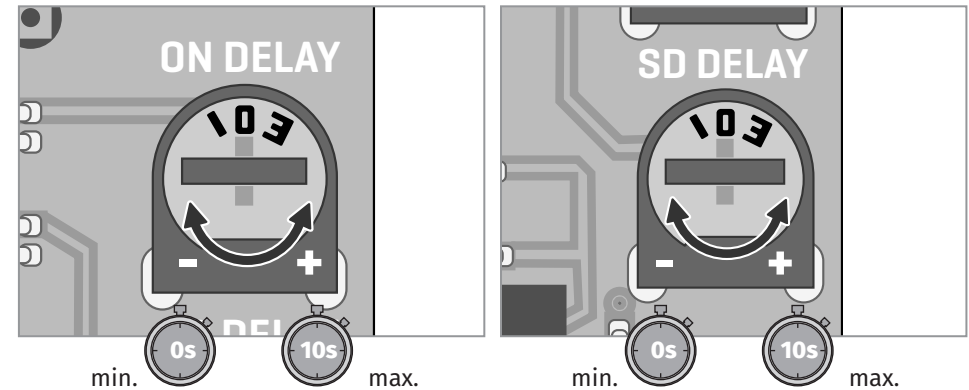

• Adjust the opening order delay time (0 to 10 seconds).

• Adjust the delay time after the motor completes the closing maneuver until the power supply to the control board is cut off.

DELAY ADJUSTMENT

When BOX APOLO receives an order, it supplies power to the engine control board and transmits the received order.

After the control board receives power, it may take a few seconds until it goes into standby and can receive maneuver orders (depending on the unit used). **This will lead to a delay between the order given by BOX APOLO and the control board.** This time must be adjusted using the **ON Delay** potentiometer.

When the automation completes the closing maneuver, BOX APOLO switches off the motor control board after the time set on the **SD Delay** potentiometer.

CHECK BATTERY STATUS

If APOLO BOX receives a maneuver order and **the battery does not have enough charge** (min. 22V), it will ignore the order received and **the LED will flash 3 times with an interval of 0.2 seconds**, to signal that the battery is discharged.

In a situation where **it is already supplying power** to execute a maneuver and the battery charge is not enough (below 22V for 2 consecutive minutes), the control board **will automatically cut the power supply** to prevent damage to the battery.

MCHSOLAR → WITHOUT AUTOMATIC CLOSING

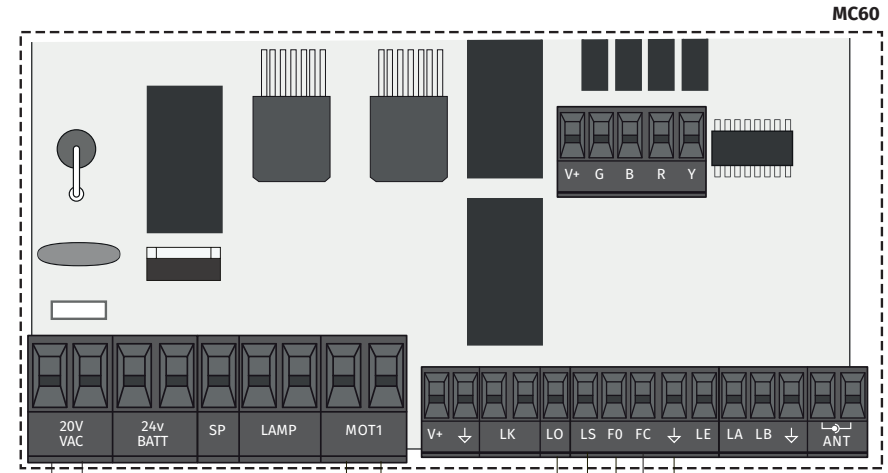
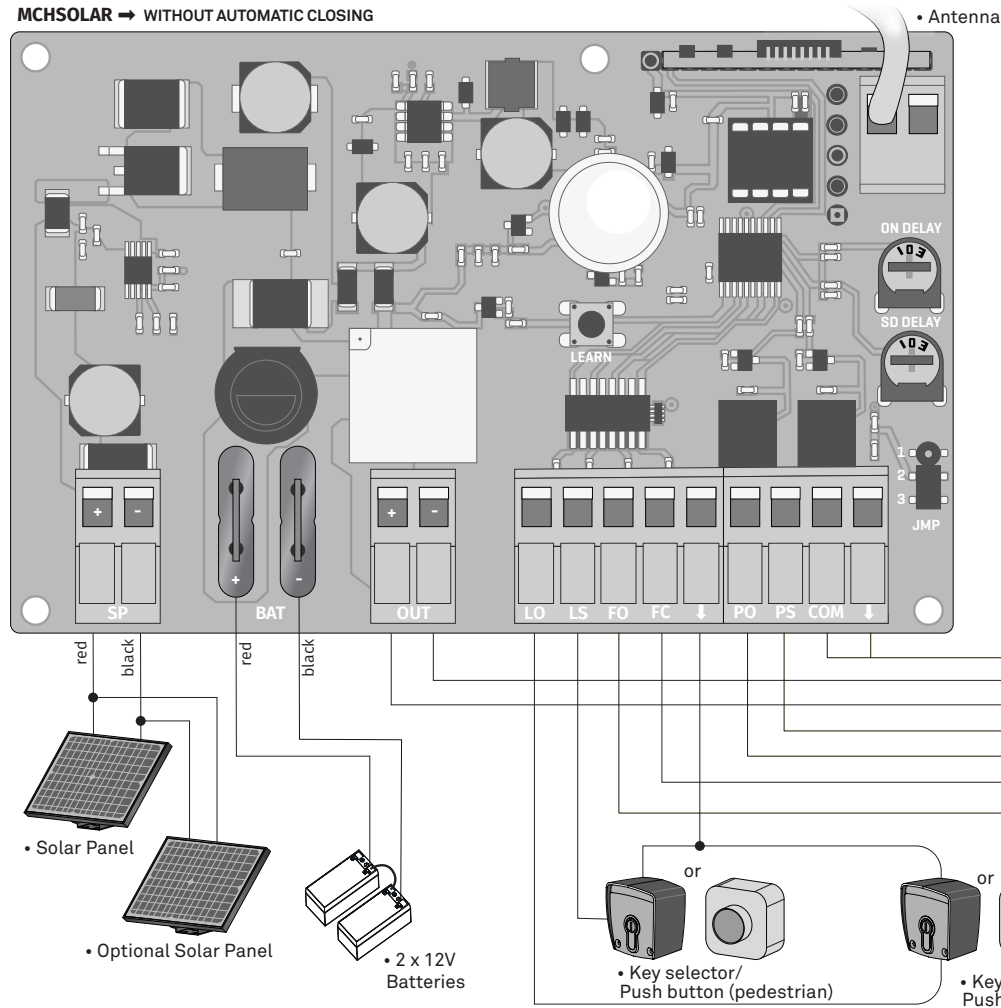

MCHSOLAR → WITH AUTOMATIC CLOSING

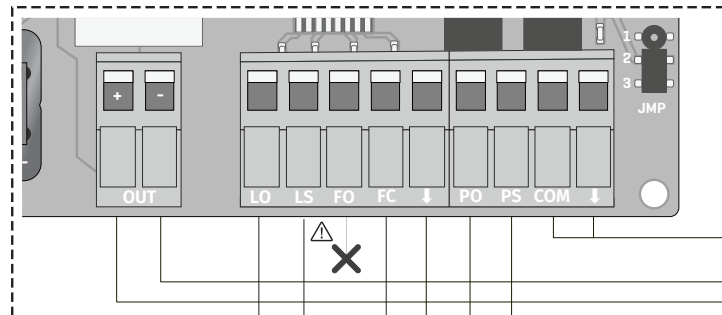

⚠ For automatic closing, do not connect the opening limit switch to the solar control board.

