



SIM

SECURITY IN MOTION

SIM-120

OUTDOOR PIR + MW DETECTOR

INSTALLATION MANUAL

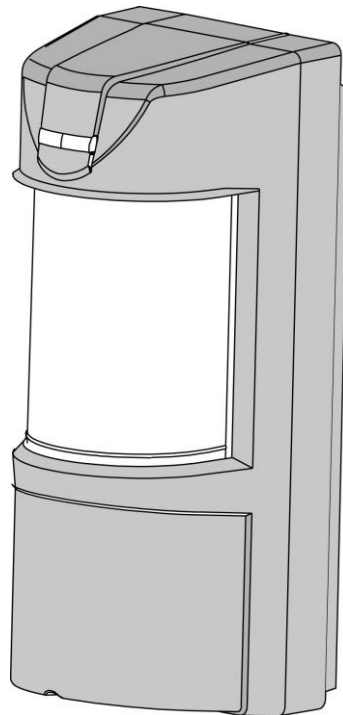

P/N 7106901 Rev. A

Table Of Content

1	General	3
2	Features.....	3
3	Assembly description:	3
4	Detection Pattern:	4
5	Selecting mounting location	5
6	Detector Installation	6
7	Terminal Block Connections	8
7.1	Wire Size Requirements	8
8	Settings & Adjustments	9
8.1	Detection beam direction	9
8.2	Detection range setting	9
8.3	Sensitivity, Range and Pet immune Adjustment	10
8.4	Indications setting	11
9	Operation	12
10	Test Procedure	12
11	Specifications.....	13

1 General

The SIM-120 is a PIR and Microwave detector for outdoor and harsh environment applications. The detection sensitivity and range is controlled by digital rotary switch allowing 16 calibration levels, so that the effective pattern will be set for every installation environment and protection site.

2 Features

- MW detection based on Doppler concept.
- N.O. & N. C. Relays switched at the same time.
- Height installation calibrations free, from 0.8m to 1.5m
- Selectable pet immunity between 20kg and 35kg.
- 16 levels of PIR sensitivity adjustment including 3 MW sensitivity groups.
- Temperature compensation.
- Front and back tamper protection.
- Sound indication for walk test and intruder detection.
- Unique waterproof and seal plastic design.
- Detection Range: Up to 15m
- Detect human intruders walking or running.

3 Assembly description:

The SIM-120 includes big indication led prism that can be easily observed from long distance. Having a back metal bracket, the SIM-120 can be easily mounted to walls and poles using mounting screws or metal bands (supplied).

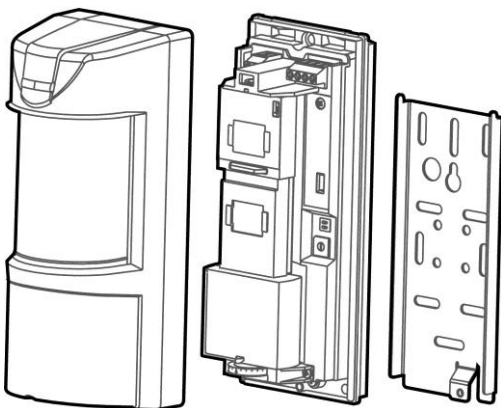

The SIM-120 is combined of three detection elements:

Upper PIR element

Lower PIR element

Microwave element

The upper PIR element has an adjustable detection height while the other two are fixed.

Internal elements:

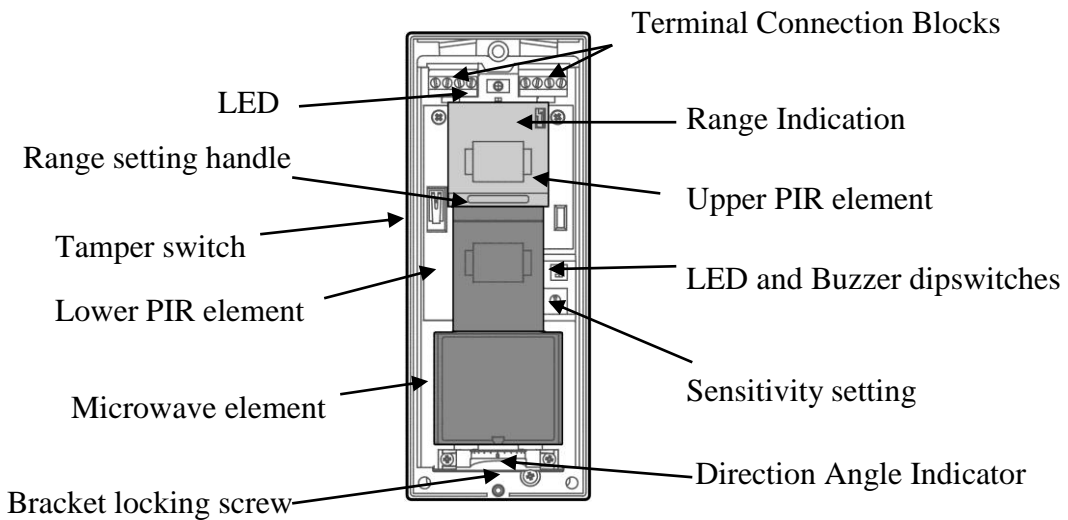

4 Detection Pattern:

The SIM-120 has a 90° top view PIR and MW detection pattern with over 15m detection distance (when installed at 1.2m above the ground surface).

The SIM-120 has an internal rotating housing (which includes the 2 PIR elements and the MW) that can be adjusted horizontally, so its 90° coverage may vary between 0° and 180°.

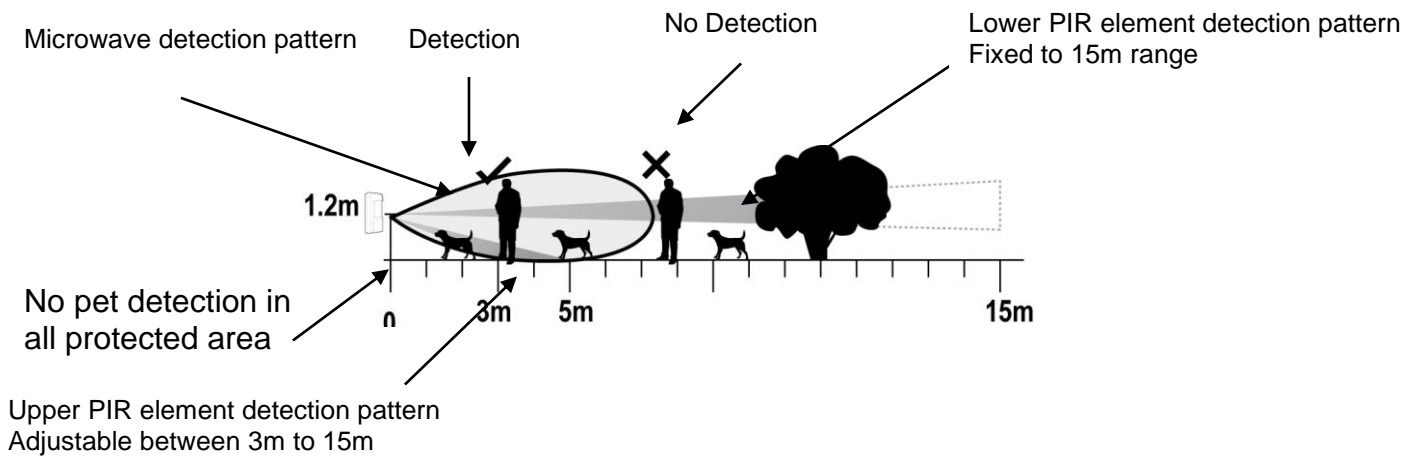
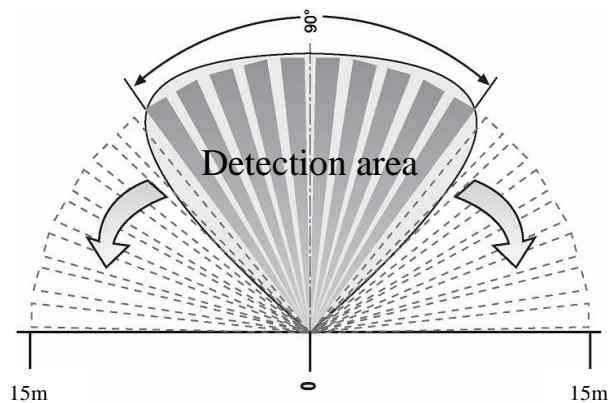

5 Selecting mounting location

The installation of the SIM-120 requires straight and solid base for the detector and setting of front panel against the center of protected area.

The protected area must be free from obstacles like walls, fences, trees, ditches and other microwave detectors, as well as systems of anti-intrusion surveillance.

The bracket provides SIM-120 installation on a wall or pole. The wall or pole should be leveled. Choose a location most likely to intercept an intruder according to detection pattern on page 6.

Avoid the following Installation Locations:

- Facing direct sunlight.
- Facing areas subject to rapid temperature changes.
- Wall angle of more than 10° from perpendicular line.
- Mounting at more than 10° Deviation from horizontal line.
- Facing metal doors.
- Do not install near direct source of heat or air gust.
- Clear all physical obstacles from the detection area (e.g. Plants, laundries, etc.)
- Clear all light reflecting surfaces from the detection area, as well as water puddles.
- Avoid installation on the following types of ground:
Thick vegetation, Grass (un-mown), Water, Sand and Metal.

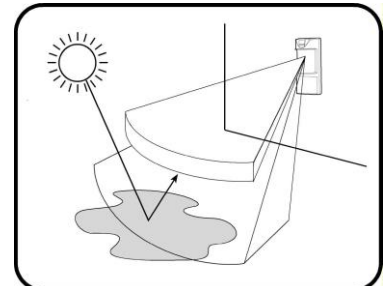
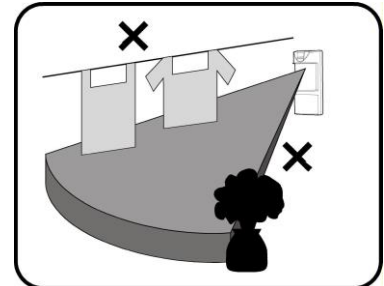
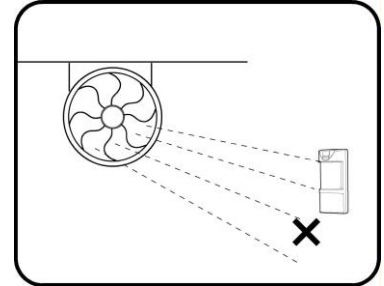

NOTE:

Recommended installation height is 4 ft (1.2m).

The SIM-120 performs best when provided with a constant and stable environment.

In order to ensure suitable operation of the SIM-120 type of ground should be one of the following: Asphalt concrete, Cement, Soil, Clay, Gravel or Grass (mown).

6 Detector Installation

1. Install the detector in such manner that the intruder is most likely to cross the detection area from side to side.

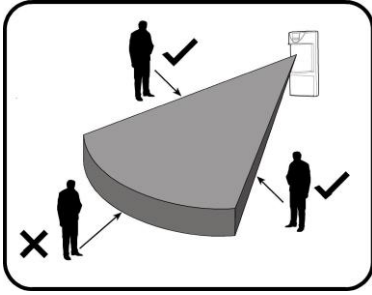

2. The detector is to be installed at height of 2.6 ft (0.8m) to 4.9 ft (1.5m)

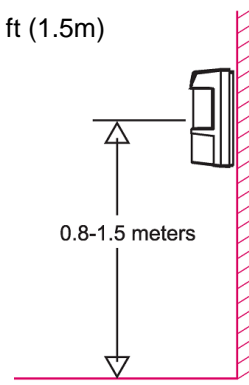

3. Make sure to attach the metal bracket to a leveled straight and firm wall, leaving 6 inches (15cm) from the top and 6 inches (15cm) from both sides, for easy installation and maintenance.

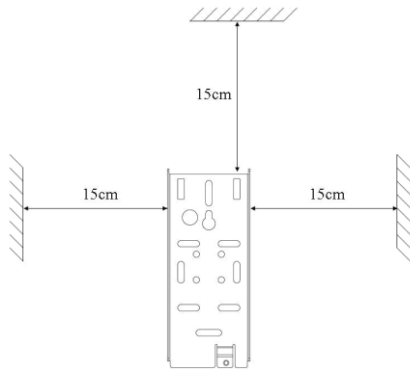

4. Rotating the detection beam may be required for guarding a side window opening while the detector is installed facing another direction.

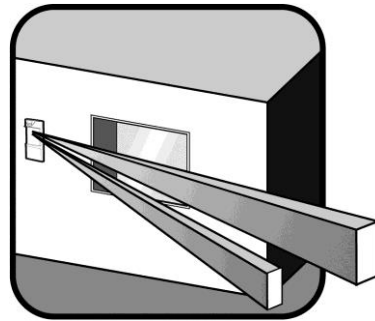

5. Open the detector unwinding the bottom screw.

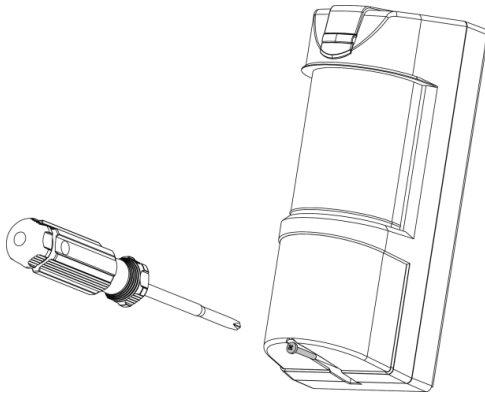

6. Release the rear metal bracket by unwinding internal bottom screw.

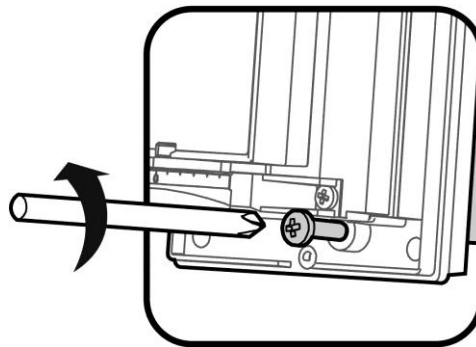

7. Release the detector body from the metal bracket by polling front and up.

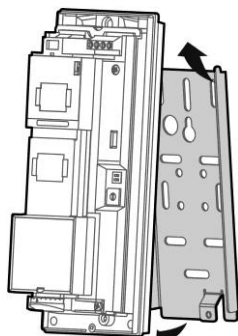

8. Attach the rear bracket to the wall or a pole using mounting screws or metal bands.

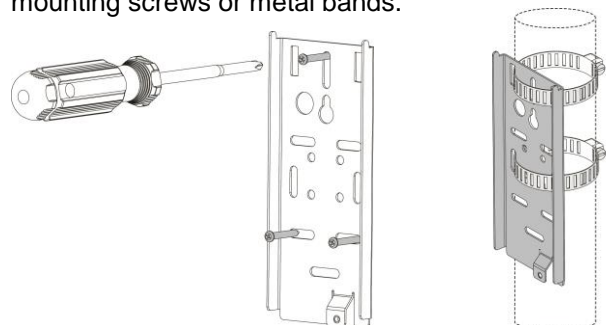

9. Break the relevant rear knockouts on plastic base rear side for your installation and slide the wires from the outside via the paths and knockout to the internal side of the detector.

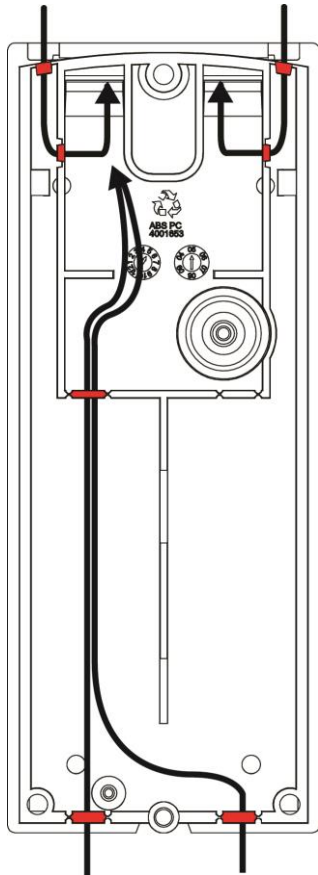

10. Attach the sealing "U" shaped Sponge Pad to the wire opening from the rear side after the wires connection and prior to final product affixing to the mounted bracket.

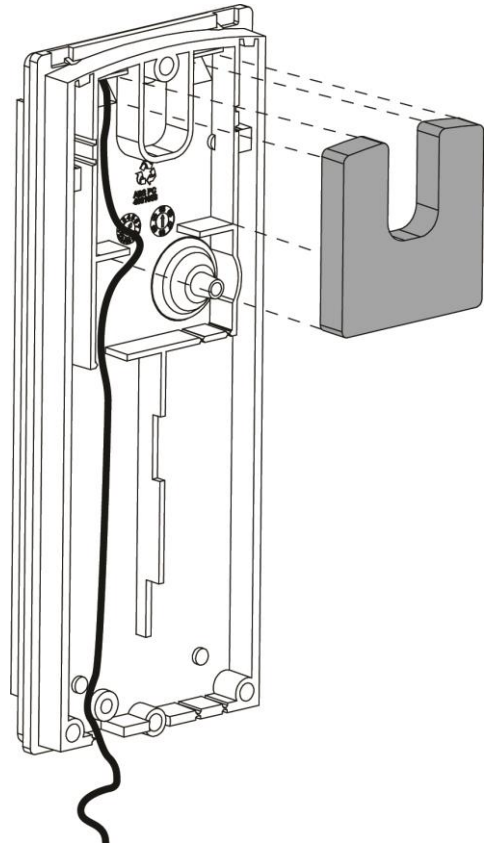

11. Place the detector on the mounting bracket from top side down and then lock the screw at the bottom.

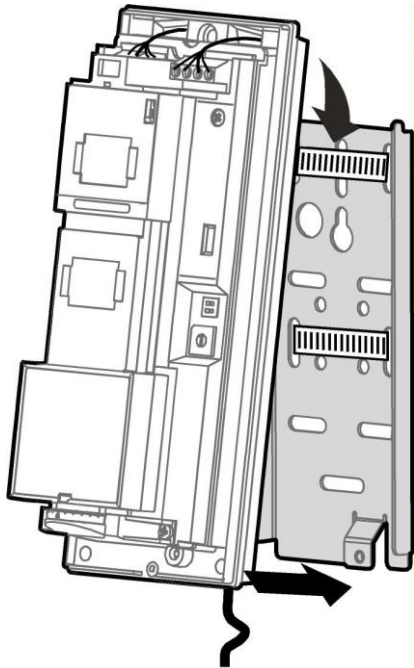

12. Connect the wires to the terminal blocks according to the following chapter.

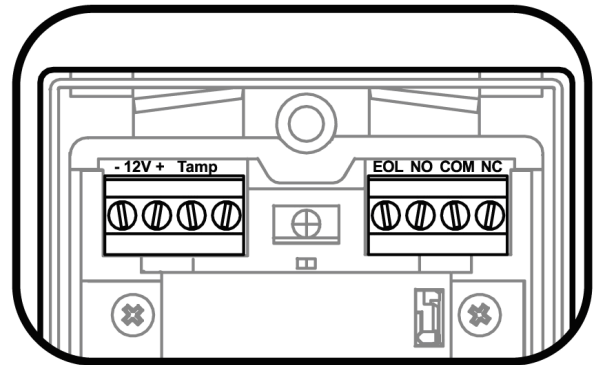

7 Terminal Block Connections

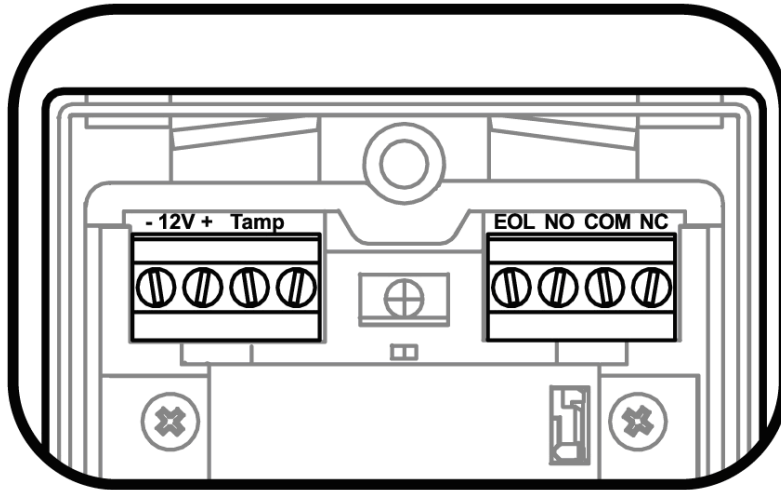

Terminal 1 - Marked “-” (GND) - Connect to the ground of the CP.

Terminal 2 - Marked “+” (+12V) - Connect to a positive Voltage of 9.6 -16Vdc source (usually from the alarm CP)

Terminals 3 & 4 - Marked “TAMP” - If a Tamper function is required connect these Terminals to a 24-hour normally closed protective zone in the CP.

If the top cover of the detector is opened or the detector is detached from installation wall, an immediate alarm signal will be sent to the CP.

Terminal 5 - Marked “EOL” - End of line – optional terminal for end of line resistors connections.

Terminals 6, 7 & 8 - Marked “NC / C / NO” - These are the output relay contacts of the detector. Connect to a normally closed or normally opened zone in the control unit. When an intruder is detected, alarm relays (N.C. and N.O.) will switch for 1.8 sec.

7.1 Wire Size Requirements

Use #22 AWG or larger wires. Use the following table to determine required wire gauge and length.

Wire Length [m]	250	350	600	1000
Wire Length [ft.]	800	1200	2000	3400
Wire Gauge [#]	22	20	18	16

8 Settings & Adjustments

8.1 Detection beam direction

The SIM-120 detection beam direction may vary between 0° and 180°.

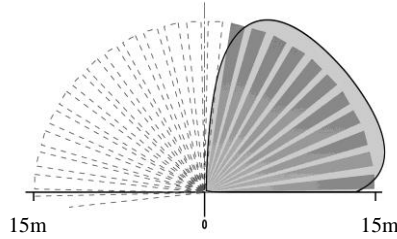

In order to change the detection beam direction rotate the internal detection element housing to the desired direction.



8.2 Detection range setting

The SIM-120 detection range may vary between 10 ft (3m) and 49 ft (15m), while installed on 4 ft (1.2m) height above the ground surface.

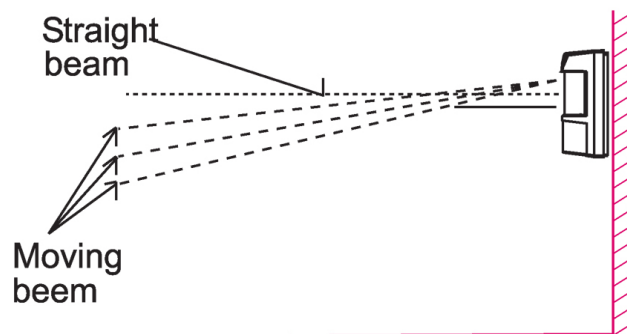

Changing the detection range is achieved by sliding the upper detection element up or down.

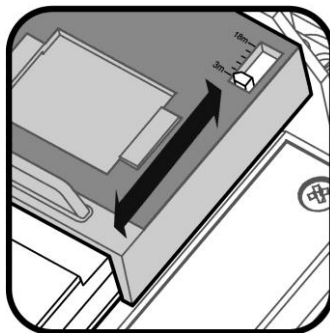

Slide the detection element down for long range or up for short range detection.



8.3 Sensitivity, Range and Pet immune Adjustment

The calibration of range and sensitivity is performed by single digital 16 position rotary switch.

There are 3 groups of switch setting according to detection range.

Each group is divided to several levels of sensitivity according to installation environment.

The sensitivity is determined by a rotating switch (16 positions). Changing the sensitivity affects immunity to environmental noises, also affects the detection distance and pet immunity level.

The rotating switch is marked with digits from “0” to “9” and following letters from “A” to “F”. Position “0” is maximum sensitivity and “F” is minimum sensitivity.

Note: Adjust sensitivity according to environmental conditions!

Group A - positions 0 – 7 – set sensitivity for 15m detection range with immunity to pets weight up to 15kg – very sensitive – 1 pulse.

Group B - positions 8 – A – set sensitivity for 10m detection range with immunity to pets weight up to 20kg – less sensitive – 2 pulses.

Group C - positions B – F – set sensitivity for 5m detection range with immunity to pets weight up to 35kg – less sensitive – 2 pulses.

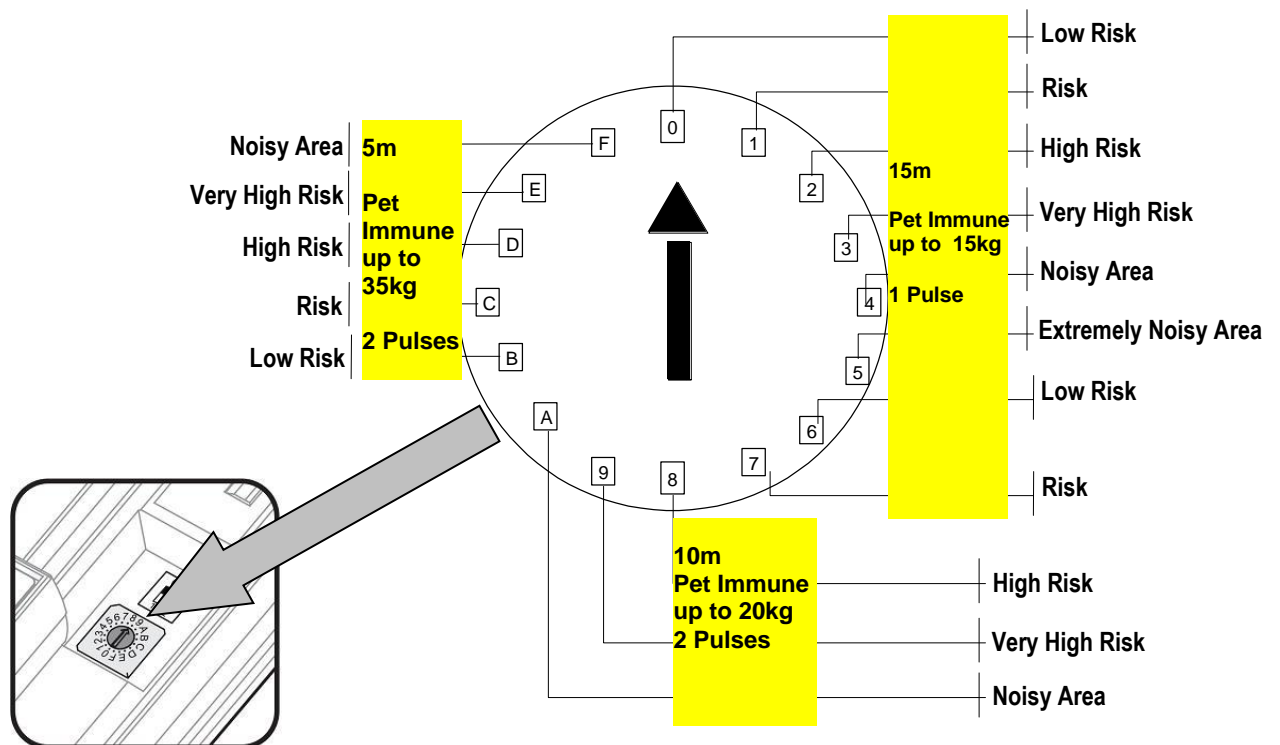

Each group is divided to 5 or 6 sub-positions that help to define the environmental condition inside the detection range:

- **Low risk:** very stable environment without interference like parking garage, under roof parking space, playground, football court, service road, etc.
- **Risk:** Stable environment with some trees, bushes, flowerpots, planters.

- High risk: Unstable environment with different types of vegetation and grass and puddles.
- Very high risk: Unstable environment with winds and small pets, rats, mice, birds.
- Noisy area: Unstable environment with vegetation and water sources like swimming pool, lake, canal, weed as well as small pets like cats and rabbits.
- Extremely Noisy area: Very unstable environment subjected to wind, snow, rain, with vegetation, water and large pets like dogs.

For example:

If detector is used for 13m range in open space with sunlight and pets, set switch to position 9.

8.4 Indications setting

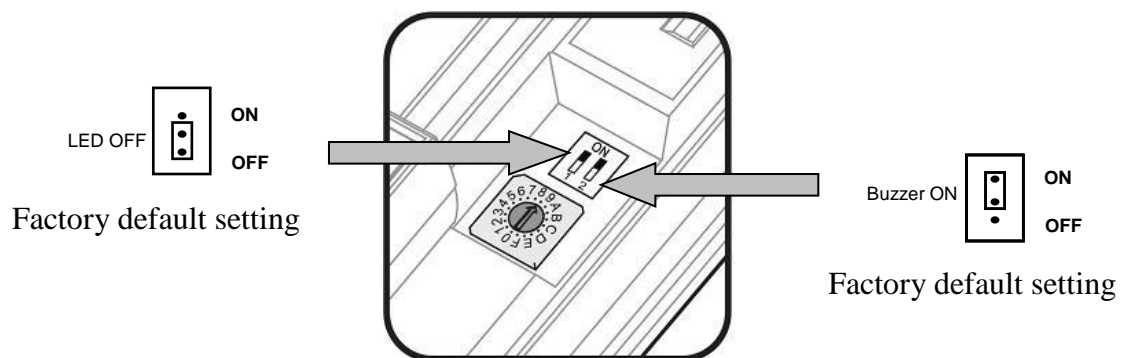

The SIM-120 has two types of indications:

1. LED
2. Buzzer

The installer may determine both indications' operation during detection (ON or OFF) by using switch number "1" for the buzzer and switch number "2" for the LED.

(Setting the buzzer ON gives the installer the ability to hear the beep on each detection for 1.8 seconds during the adjustments and a walk test. After the process it is recommended to switch the buzzer OFF)

- Place the top cover to the base and close it using the bottom screw.

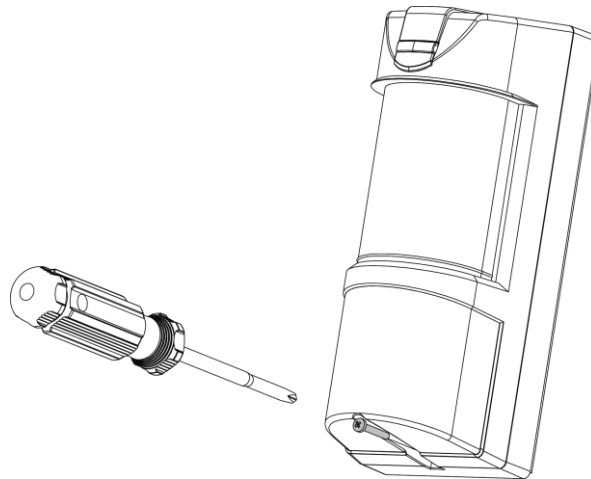

9 Operation

Note! Connect the SIM-120 to a positive Voltage output of 9.6 -16VDC source.

Use only a listed power limited source.

The detector shall be provided with minimum of 4 hours of standby power from either a listed compatible control unit or power supply.

- The detector is automatically operated once connected to power.
- The LED starts flashing for 30 seconds during the setup period and after that it will turn off.
- At this time the detector is ready for operation.

10 Test Procedure

Walk Test

Allow 2 minutes of warm up time.

Make sure that the protected area is cleared of all people.

Start walking across the detection zone.

Listen to ALARM sound whenever motion is detected (the red LED also turns ON whenever motion is detected).

Allow 5 sec. between each test for the detector to stabilize.

Upon installation, the unit should be thoroughly tested to verify proper operation.

Walk across the entire area where coverage is desired. Should the coverage be incomplete, readjust coverage range or relocate the detector.

Once coverage is as desired, the alarm buzzer should be disabled and the LED may be disabled.

11 Specifications

Detection Method	Double PIR AND MW
Microwave Frequency	24.125 GHz
Power Input	9.6 to 16Vdc
Current Draw	Active: 24mA ($\pm 5\%$) Standby: 21mA ($\pm 5\%$)
Temp Compensation	Yes, Dual slop temperature compensation
Alarm Period	2 sec (± 0.5 sec)
Alarm Outputs	Form C (NC, NO, Common) 28Vdc 0.1 A with 10 Ohm
Tamper Switch(s)	Two Switches N.C 28Vdc 0.1A with 10 Ohm Series protection resistors Opens when cover is removed from unit's base
Warm up Period	120sec (± 5 sec)
LED Indicator	LED is ON during ALARM
RF Immunity	10 V/m plus 80% AM from 80 MHz to 2GHz
Electro Static Immunity	6kV contact, 8kV air
Transient Immunity	1kV
Operation Temp	-35°C ~ +55°C
Dimensions	200mm x 86mm x 80mm
Weight	500gr.
Protection Degree	IP 65



SIM

SECURITY IN MOTION

www.sim-security.net